



Technology Solutions

TEK-VOR 1300C

Vortex Mass Flowmeter



FLOW



Introduction

A Tek-Vor 1300C Vortex Flowmeter (also called a Vortex Shedding Flowmeter) is a versatile instrument that calculates the mass flow, volumetric flow rate, temperature, and pressure and density of any liquid, gas, or steam through a pipeline. Widespread application is found in several industries including Petrochemical, Chemical, Pharmaceutical, Food and Beverage, Water, and Wastewater Treatment.

Measuring Principle

Karman Vortex Street

This flowmeter operates on the principle of Karman Vortex Street, any medium passing through the pipeline flows around the bluff body and sheds a series of alternating vortices on each side of the body. This phenomenon is referred to as Vortex Shedding. These vortices shed downstream of the bluff body and dissipate as they flow further. This pattern of vortices is called a Karman Vortex Street (also called a Von Karman Vortex Street).

Operation

A Vortex flowmeter primarily consists of a bluff body, a sensor assembly, and a transmitter. A bluff body or a shedder is nothing but a non-streamlined object or a barrier placed perpendicular to the axis of the pipeline, around which the medium flows.

Calculation of the Mass Flow Rate

The frequency of the vortices, i.e. the number of vortices shed per second, is directly proportionate to the velocity of the medium. This Vortex Shedding Frequency is used to calculate the mass flow.

The sensor assembly records the pressure and velocity oscillations generated on each side of the bluff body by the vortices and generate a digital linear output signal. The Vortex Shedding Frequency is calculated using the following formula:

$$f = S_t * V/d$$

Where:

f = Frequency of Vortex Shedding

S_t = Strouhal Number

V = Flow Velocity

d = Width of the Bluff Body

Strouhal Number S_t

The Strouhal Number in the above formula is also called as "reduced frequency". It is a dimensionless parameter that is a measure of the Vortex Shedding Frequency and the velocity of the flow medium. It is calculated using the formula:

$$S_t = fd/U$$

Where:

f = Frequency of Vortex Shedding

d = Width of the Bluff Body

U = Velocity of the Flow Medium

The Strouhal Number is a function of the Reynold's Number. Reynold's Number is also a dimensionless parameter that is used to determine how the flow pattern of different fluids will change. The Strouhal Number should remain constant when the Reynold's Number ranges from 2×10^4 to 7×10^6 .

Calculation of Volume Flow Rate

When the Vortex Shedding Frequency is known, the volumetric flow rate can be calculated using the formula:

$$q = f/k * d$$

Where:

q = Volumetric Flow Rate

f = Vortex Shedding Frequency

k = k Factor, which is a ratio of the pulses transmitted to the unit volume

Benefits

- High stability and accuracy.
- Unique Dual Sensor design.
- Special signal processing method providing better anti-vibration.
- Reliable performance.
- Low Maintenance.
- Calculates Density and Mass Flow.
- Self-diagnostic function.
- Optional Bluetooth function- read flow rate on smart phones.
- Optional multivariable version.
- In-built RTD and Pressure Sensor with display and measurement for flow rate, velocity, temperature, pressure, mass flow rate and density.

Applications

- It is used to measure gas, steam, and liquid.
- Cleaning and Sterilization (SIP and CIP) process in food, beverage, and pharmaceutical industries.
- It is used in various industries like petrochemical, water and waste water, food and beverages.

Dimensional Drawing

Size and Dimension for Wafer Type

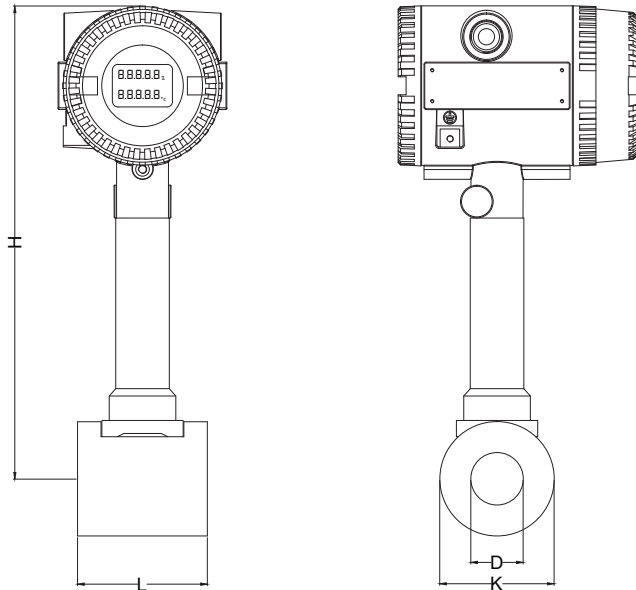

D Size In. (ft)	K Pipe OD In. (ft)	L Pipe Length In. (ft)	Flange Screw Hole Distance In. (ft)	Flange Thickness In. (ft)	Screw Hole Diameter In. (ft)	Screw qty.	H Meter Height In. (ft)	Flange OD in. (ft)
1" (0.08)	3.30" (0.27)	2.55" (0.21)	3.93" (0.32)	0.70" (0.05)	0.51" (0.04)	4	11.35" (0.94)	5.11" (0.42)
1½" (0.12)	3.58" (0.29)	2.55" (0.21)	4.72" (0.39)	0.78" (0.06)	0.51" (0.04)	4	11.63" (0.96)	5.70" (0.47)
2" (0.16)	3.7" (0.30)	2.55" (0.21)	5.19" (0.43)	0.86" (0.07)	0.66" (0.05)	4	11.85" (0.98)	6.29" (0.52)
3" (0.25)	4.27" (0.35)	2.55" (0.21)	6.29" (0.52)	0.94" (0.07)	0.66" (0.05)	6	12.44" (1.03)	7.55" (0.62)
4" (0.33)	5.51" (0.45)	3.54" (0.29)	7.48" (0.62)	0.94" (0.07)	0.66" (0.05)	8	12.87" (1.07)	9.05" (0.75)
6" (0.5)	7.48" (0.62)	2.55" (0.21)	9.44" (0.78)	1.10" (0.09)	0.82" (0.06)	8	13.89" (1.15)	11.02" (0.91)
8" (0.66)	9.44" (0.78)	3.34" (0.27)	11.65" (0.97)	1.10" (0.09)	0.82" (0.06)	12	14.88" (1.24)	13.18" (1.09)
10" (0.83)	11.41" (0.95)	3.93" (0.32)	13.93" (1.16)	1.10" (0.09)	0.82" (0.06)	12	15.90" (1.32)	15.94" (1.32)
12" (1)	13.38" (1.11)	4.72" (0.39)	16.22" (1.35)	1.18" (0.09)	0.82" (0.06)	12	16.88" (1.40)	18.11" (1.50)

Size and Dimension for Flanged Type

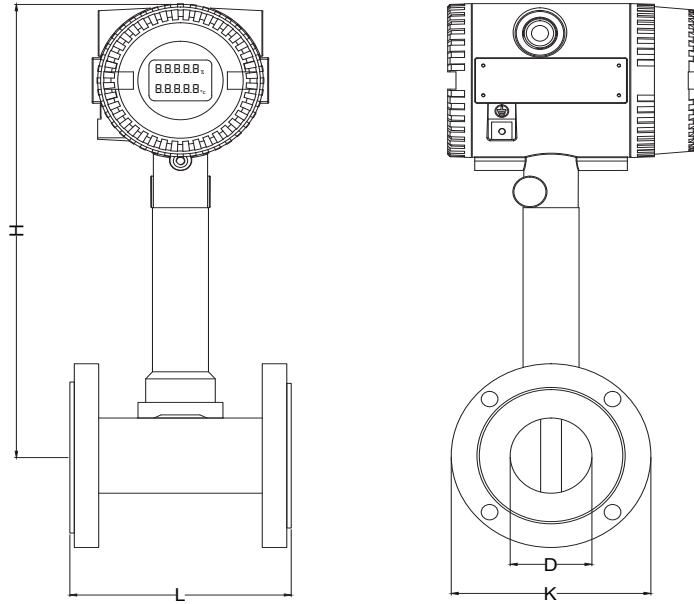

Dimension for ANSI CL150 Flanged

D Size In. (ft)	K Pipe OD In. (ft)	L Pipe Length In. (ft)	Flange Screw Hole Distance In. (ft)	Flange Thickness In. (ft)	Screw Hole Diameter In. (ft)	Screw qty.	H Meter Height In. (ft)
1" (0.08)	4.33" (0.36)	7.08" (0.59)	3.12" (0.26)	0.57" (0.04)	0.62" (0.05)	4	11.63" (0.96)
1½" (0.12)	4.92" (0.41)	7.08" (0.59)	3.87" (0.32)	0.70" (0.05)	0.62" (0.05)	4	11.90" (0.99)
2" (0.16)	5.90" (0.49)	7.08" (0.59)	4.75" (0.39)	0.76" (0.06)	0.74" (0.06)	4	12.08" (1)
3" (0.25)	7.48" (0.62)	7.87" (0.65)	6" (0.5)	0.95" (0.07)	0.74" (0.06)	4	12.86" (1.07)
4" (0.33)	9.05" (0.75)	8.66" (0.72)	7.5" (0.62)	0.95" (0.07)	0.74" (0.06)	8	13.22" (1.10)
6" (0.5)	11.02" (0.91)	8.66" (0.72)	9.5" (0.79)	1.01" (0.08)	0.86" (0.07)	8	14.17" (1.18)
8" (0.66)	13.58" (1.13)	8.66" (0.72)	11.75" (0.97)	1.14" (0.09)	0.86" (0.07)	8	15.15" (1.26)
10" (0.83)	15.94" (1.32)	9.84" (0.82)	14.25" (1.18)	1.20" (0.1)	0.86" (0.07)	12	16.24" (1.35)
12" (1)	19.09" (1.59)	11.81" (0.98)	17" (1.41)	1.26" (0.10)	0.86" (0.07)	12	17.53" (1.46)

Size and Dimension for Multi-Variable Wafer Type

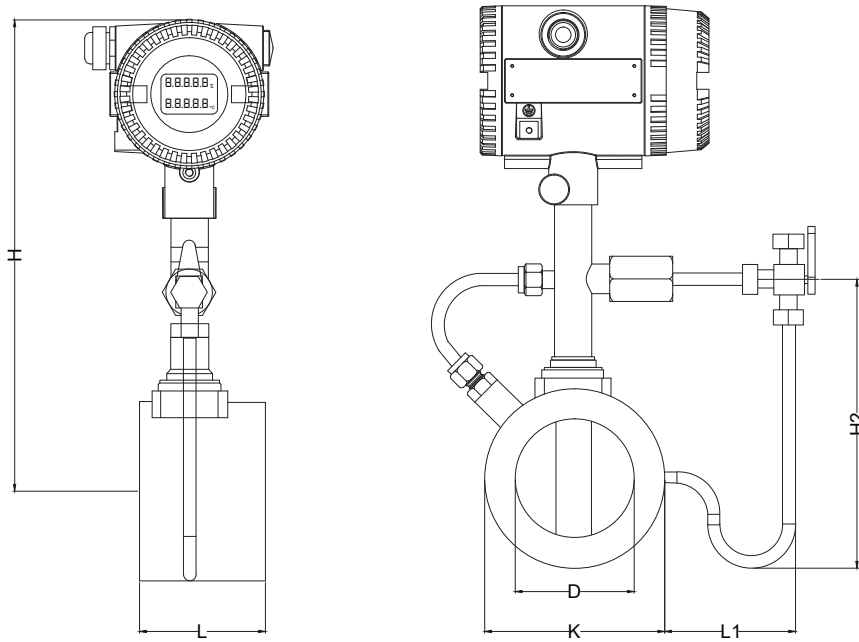

D Size In. (ft)	K Pipe OD In. (ft)	L Pipe Length In. (ft)	Flange Screw Hole Distance In. (ft)	Flange Thick- ness In. (ft)	Screw Hole Diameter In. (ft)	Screw qty.	H Meter Height In. (ft)	Flange OD In. (ft)	H2 Conden- sation Pipe Height In. (ft)	L1 Conden- sation Pipe Length In. (ft)
1" (0.08)	3.30" (0.27)	2.55" (0.21)	3.93" (0.32)	0.70" (0.05)	0.51" (0.04)	4	11.35" (0.94)	5.11" (0.42)	5.74" (0.47)	5.35" (0.44)
1½" (0.12)	3.58" (0.29)	2.55" (0.21)	4.72" (0.39)	0.78" (0.06)	0.51" (0.04)	4	11.63" (0.96)	5.70" (0.47)	6.21" (0.51)	5.07" (0.42)
2" (0.16)	3.7" (0.30)	2.55" (0.21)	5.19" (0.43)	0.86" (0.07)	0.66" (0.05)	4	11.85" (0.98)	6.29" (0.52)	6.61" (0.55)	4.88" (0.40)
3" (0.25)	4.27" (0.35)	2.55" (0.21)	6.29" (0.52)	0.94" (0.07)	0.66" (0.05)	4	12.44" (1.03)	7.55" (0.62)	8.11" (0.67)	4.29" (0.35)
4" (0.33)	5.51" (0.45)	3.54" (0.29)	7.48" (0.62)	0.94" (0.07)	0.66" (0.05)	8	12.87" (1.07)	9.05" (0.75)	8.54" (0.71)	3.89" (0.32)
6" (0.5)	7.48" (0.62)	2.55" (0.21)	9.44" (0.78)	1.10" (0.09)	0.82" (0.06)	8	13.89" (1.15)	11.02" (0.91)	10.55" (0.87)	3.89" (0.32)
8" (0.66)	9.44" (0.78)	3.34" (0.27)	11.65" (0.97)	1.10" (0.09)	0.82" (0.06)	8	14.88" (1.24)	13.18" (1.09)	12.51" (1.04)	3.89" (0.32)
10" (0.83)	11.41" (0.95)	3.93" (0.32)	13.93" (1.16)	1.10" (0.09)	0.82" (0.06)	12	15.90" (1.32)	15.94" (1.32)	14.52" (1.21)	3.89" (0.32)
12" (1)	13.38" (1.11)	4.72" (0.39)	16.22" (1.35)	1.18" (0.09)	0.82" (0.06)	12	16.88" (1.40)	18.11" (1.50)	16.49" (1.37)	3.89" (0.32)

Size and Dimension for Multi-Variable Flanged Type

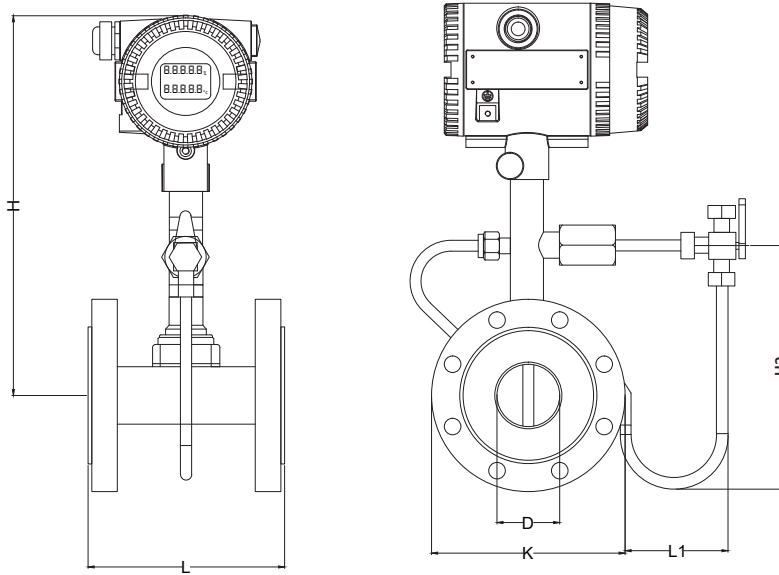

Dimension for Flanged Multi-Variable Type (ANSI CL150)

D Size In. (ft)	K Pipe OD In. (ft)	L Pipe Length In. (ft)	Flange Screw Hole Distance In. (ft)	Flange Thickness In. (ft)	Screw Hole Diameter In. (ft)	Screw qty.	H Meter Height In. (ft)	H2 Conden- sation Pipe Height In. (ft)	L1 Conden- sation Pipe Length In. (ft)
1" (0.08)	4.33" (0.36)	7.08" (0.59)	3.12" (0.26)	0.57" (0.04)	0.62" (0.05)	4	11.63" (0.96)	6.71" (0.55)	5.35" (0.44)
1½" (0.12)	4.92" (0.41)	7.08" (0.59)	3.87" (0.32)	0.70" (0.05)	0.62" (0.05)	4	11.90" (0.99)	7.28" (0.60)	5.07" (0.42)
2" (0.16)	5.90" (0.49)	7.08" (0.59)	4.75" (0.39)	0.76" (0.06)	0.74" (0.06)	4	12.08" (1)	7.95" (0.66)	4.88" (0.40)
3" (0.25)	7.48" (0.62)	7.87" (0.65)	6" (0.5)	0.95" (0.07)	0.74" (0.06)	4	12.86" (1.07)	9.48" (0.79)	4.29" (0.35)
4" (0.33)	9.05" (0.75)	8.66" (0.72)	7.5" (0.62)	0.95" (0.07)	0.74" (0.06)	8	13.22" (1.10)	10.66" (0.88)	3.89" (0.32)
6" (0.5)	11.02" (0.91)	8.66" (0.72)	9.5" (0.79)	1.01" (0.08)	0.86" (0.07)	8	14.17" (1.18)	12.59" (1.04)	3.89" (0.32)
8" (0.66)	13.58" (1.13)	8.66" (0.72)	11.75" (0.97)	1.14" (0.09)	0.86" (0.07)	8	15.15" (1.26)	14.86" (1.23)	3.89" (0.32)
10" (0.83)	15.94" (1.32)	9.84" (0.82)	14.25" (1.18)	1.20" (0.1)	0.98" (0.08)	12	16.24" (1.35)	17.13" (1.42)	3.89" (0.32)
12" (1)	19.09" (1.59)	11.81" (0.98)	17" (1.41)	1.26" (0.10)	0.98" (0.08)	12	17.53" (1.46)	19.99" (1.66)	3.89" (0.32)

Specifications

Nominal Diameter	1" to 12" (0.04 ft to 1 ft)		
Measurement Range in Ft/sec (m/s)	Size	1" (0.08 ft)	1 ½" to 12" (0.12 to 1 ft)
	Fluid Flow Rate	Steam	13.12 to 229.6 ft/sec (4 to 70 m/s) 6.56 to 229.6 ft/sec (2 to 70 m/s)
		Gas	13.12 ft/sec to 196.85 ft/sec (4 to 60 m/s) 6.56 to 196.85 ft/sec (2 to 60 m/s)
		Liquid	0.98 to 22.96 ft/sec (0.3 to 7 m/s) 0.98 to 22.96 ft/sec (0.3 to 7 m/s)
Accuracy	±1% of Reading For Multivariable Version: Temperature ±1 °F, Pressure: 0.75% FS		
Repeatability	0.3% of F.S.		
Output	4 to 20 mA and Pulse 4 to 20 mA, Pulse and HART 4 to 20 mA, Pulse and RS485 modbus		
Maximum Process Pressure Limit	AS Per Flange Rating		
Process Temperature Range	-40 °F to 302 °F (-40 °C to 150 °C) or -40 °F to 482 °F (-40 °C to 250 °C) or -40 °F to 662 °F (-40 °C to 350 °C)		
Ambient Humidity	5 to 100% RH		
Process Connection	Wafer, CL150 ANSI Flange, CL300 ANSI Flange		
Electrical Connection	½" NPT		
Material	304 SS, 316 SS		

Installation

Standard Installation

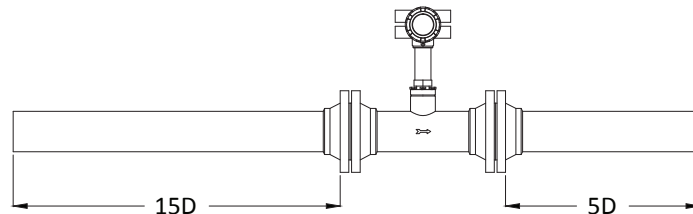

Installation for Pipe Reducer

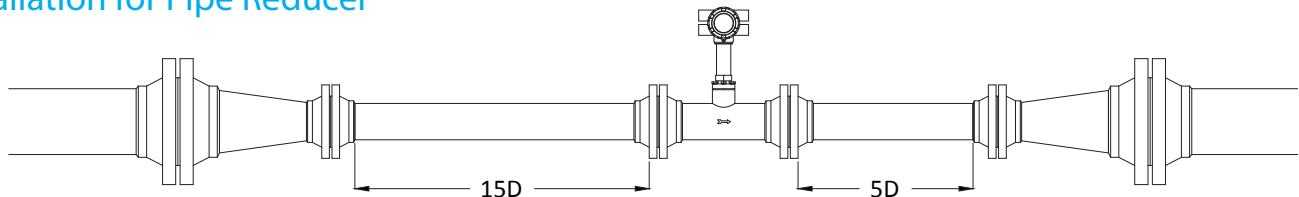

Installation for Pipe Expander

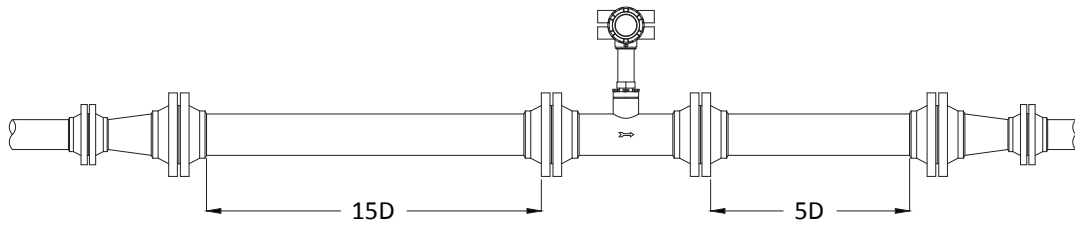

Installation for Single Bend Pipeline

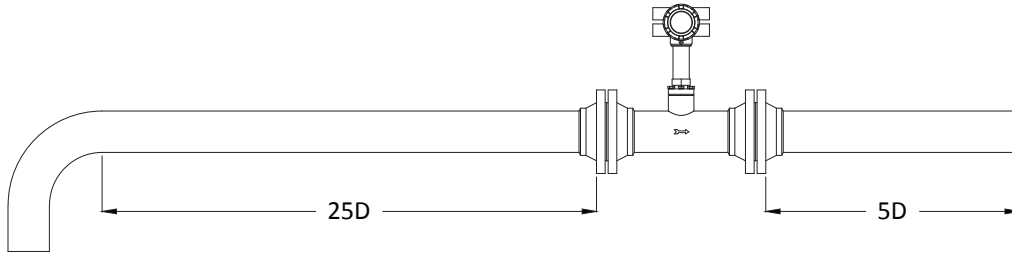

Installation for Double Bend Pipeline

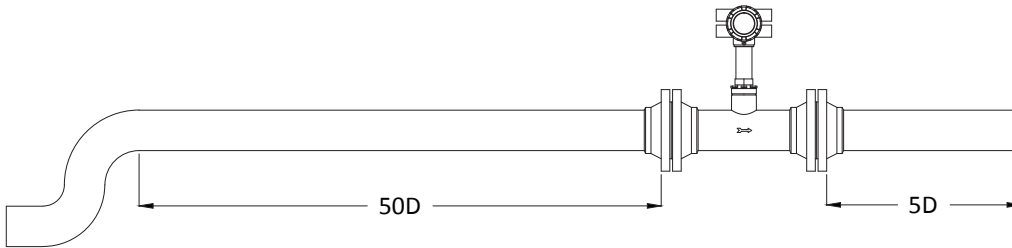

Installation when Valve is at Downstream

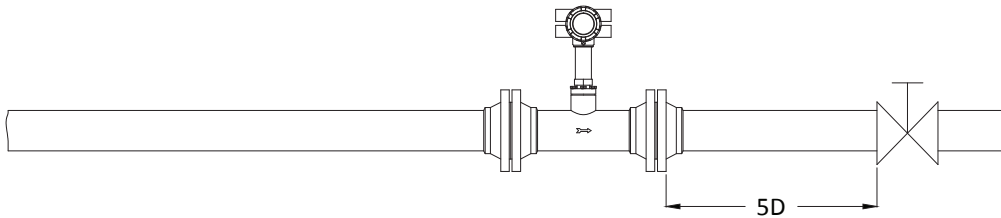

Installation when Valve is at Upstream

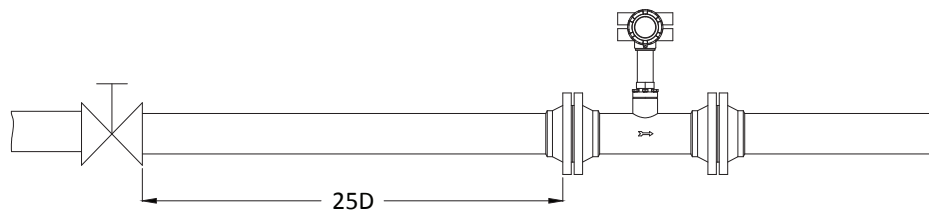

Installation when Temperature and Pressure Sensor are at Downstream

2D to 7D downstream of flowmeter and Temperature sensor: 1D to 2D downstream of pressure sensor.

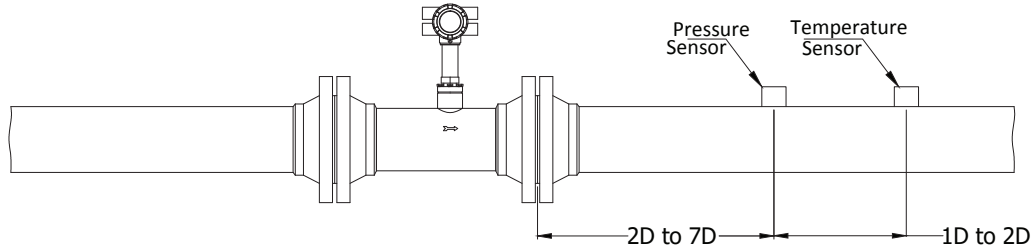

Installation when Roots Blower or Piston Blower or Air Compressor are at Upstream

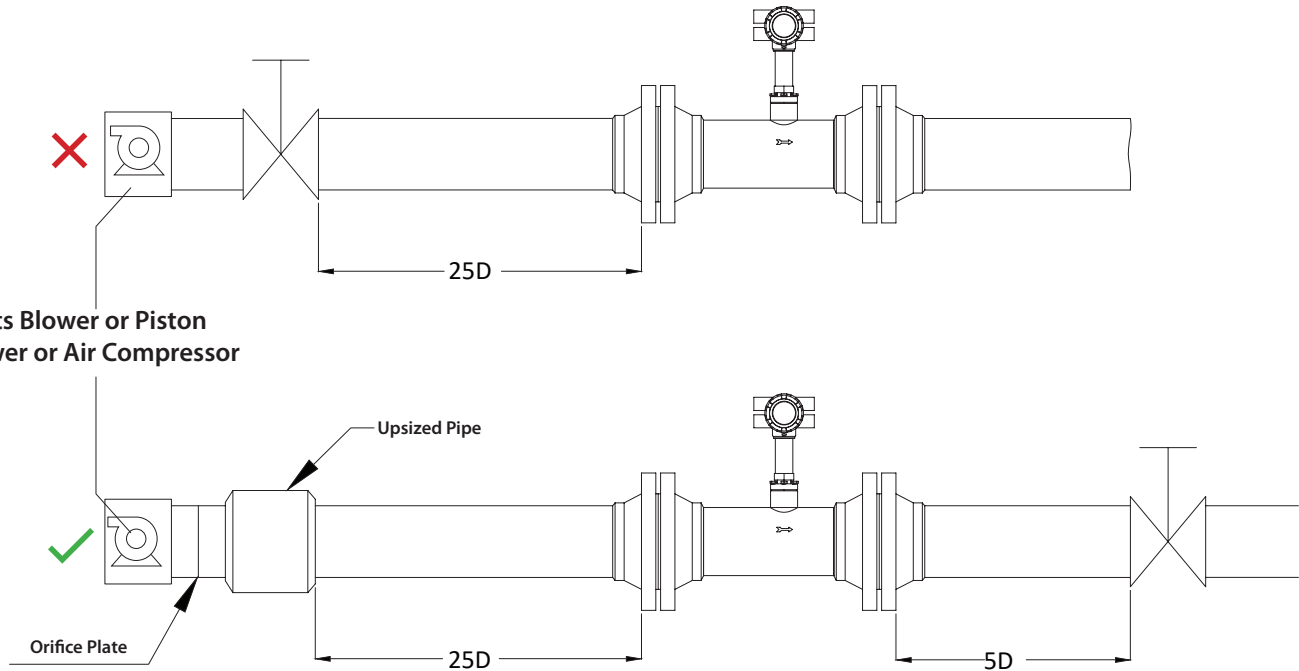

Note:

Roots blower or piston blower or air compressor or pump in Upstream, could cause vibration of the fluid itself. To eliminate this vibration, please install an orifice plate or an upsized pipe at about 25D upstream of the flowmeter, the valve should be located downstream of the flowmeter in this condition.

Installation for Flowmeter after a Piston Pump

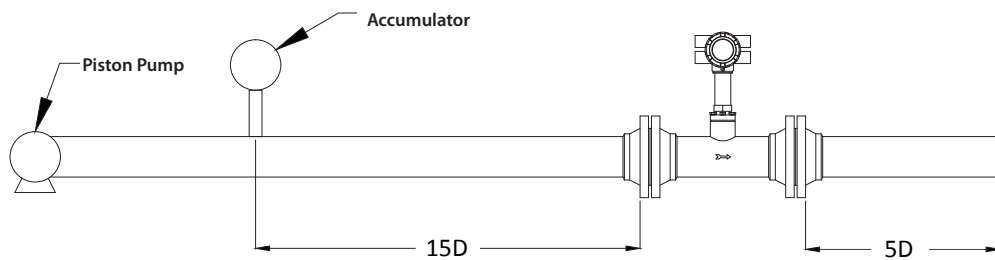

Note:

Please install an accumulator to reduce the vibration.

Installation when T Type Pipeline is at Upstream

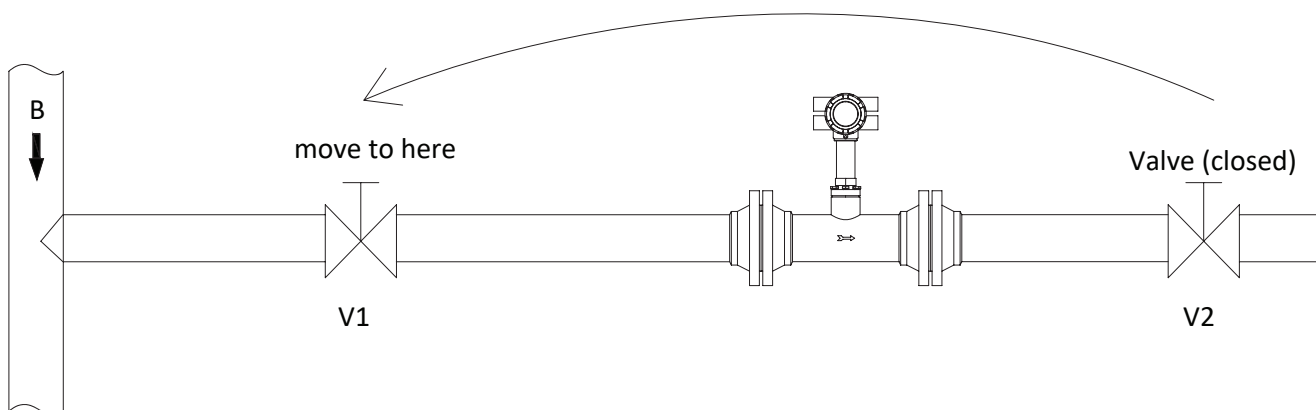

Note:

When the downstream valve (V2) is closed on a T pipe, residual fluid will still move through the flowmeter causing erroneous readings. To correct this please move the valve to the upstream of the meter. Please move the valve to the upstream of the meter to avoid this happening.

Tek-trol Bluetooth or Tek Bluetooth

How to download the application

- Visit Apple's app store
- Search "Tek-trol Bluetooth" or "Tek Bluetooth"
- Download the application



Visit Apple's app store and search for tek-bluetooth, download and you're set!

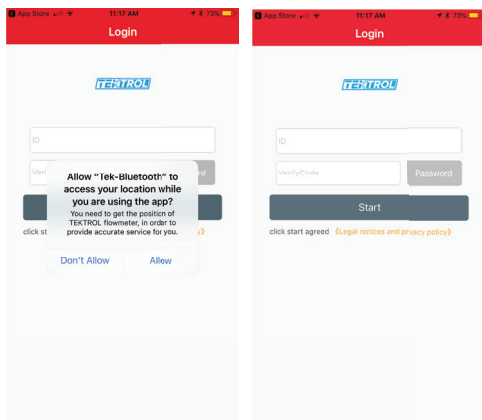

Access the application

- Open Application
- Enter login information (Example: ID: 00000000000, Verify code: 000000)
- This will take you to "device list" where your phone will automatically sync with your product (you have to be close enough)

Utilize the application

Follow prompts and menu to navigate through the many features of our Bluetooth application.



Model Chart

Example	Tek-Vor 1300C	050S	W	I	M	1	B	Tek-Vor 1300C-050S-W-I-M-1-B
Series	Tek-Vor 1300C							Vortex Mass Flowmeter
Size		025S 040S 050S 080S 100S 150S 200S 250S 300S 025M 040M 050M 080M 100M 150M 200M 250M 300M						1", ±1.0% Accuracy, Standard Vortex Meter 1-½", ±1.0% Accuracy, Standard Vortex Meter 2", ±1.0% Accuracy, Standard Vortex Meter 3", ±1.0% Accuracy, Standard Vortex Meter 4", ±1.0% Accuracy, Standard Vortex Meter 6", ±1.0% Accuracy, Standard Vortex Meter 8", ±1.0% Accuracy, Standard Vortex Meter 10", ±1.0% Accuracy, Standard Vortex Meter 12", ±1.0% Accuracy, Standard Vortex Meter 1", ±1.0% Accuracy, Multi-Variable Vortex Meter 1-½", ±1.0% Accuracy, Multi-Variable Vortex Meter 2", ±1.0% Accuracy, Multi-Variable Vortex Meter 3", ±1.0% Accuracy, Multi-Variable Vortex Meter 4", ±1.0% Accuracy, Multi-Variable Vortex Meter 6", ±1.0% Accuracy, Multi-Variable Vortex Meter 8", ±1.0% Accuracy, Multi-Variable Vortex Meter 10", ±1.0% Accuracy, Multi-Variable Vortex Meter 12", ±1.0% Accuracy, Multi-Variable Vortex Meter
Process Connection			W F T					Wafer (Comes with two CL150 ANSI Flange adapters) CL150 ANSI Flange CL300 ANSI Flange
Output				I H R				4-20 mA, Pulse 4-20 mA with HART RS485
Temperature Rating					S M H			302 °F (150 °C) 482 °F (250 °C) 662 °F (350 °C) (Standard Vortex Only)
Transmitter						1 2		Direct Mount Remote Mount (comes with 5 meters of cable)
Diagnostics							B	Bluetooth

Popular Models

Model Number	Description
1300C-025M-W-I-M-1-B	1" Multi-Variable, Wafer, Direct Mount, Bluetooth, 482 °F
1300C-050M-W-I-M-1-B	2" Multi-Variable, Wafer, Direct Mount, Bluetooth, 482 °F
1300C-080M-W-I-M-1-B	3" Multi-Variable, Wafer, Direct Mount, Bluetooth, 482 °F
1300C-100M-W-I-M-1-B	4" Multi-Variable, Wafer, Direct Mount, Bluetooth, 482 °F
1300C-025S-W-I-M-1-B	1", Wafer, Direct Mount, Bluetooth, 482 °F
1300C-050S-W-I-M-1-B	2", Wafer, Direct Mount, Bluetooth, 482 °F
1300C-080S-W-I-M-1-B	3", Wafer, Direct Mount, Bluetooth, 482 °F
1300C-100S-W-I-M-1-B	4", Wafer, Direct Mount, Bluetooth, 482 °F

Customer Service and Support



TEKMATION LLC reserves the right to change the designs and/or materials of its products without notice. The contents of this publication are the property of TEKMATON and cannot be reproduced by any other party without written permission. All rights reserved. Copyright © 2019 TEKMATON LLC
TEKMATION LLC
DOC # TEK/PO/191125/TEK-VOR/13



www.tek-trol.com

Tek-Trol is a fully owned subsidiary of TEKMATON LLC. We offer our customers a comprehensive range of products and solutions for process, power, and oil and gas industries. Tek-Trol provides process measurement and control products for Flow, Level, Temperature and Pressure Measurement, Control Valves, and Analyzer systems. We are present in 15 locations globally and are known for our knowledge, innovative solutions, reliable products, and global presence.

Tek-Trol LLC

796 Tek Drive Crystal Lake, IL 60014 USA
Tel: +1 847 857 6076, +1 847 655 7428 Fax: +1 847 655 6147
Email: tektrol@tek-trol.com
www.tek-trol.com